



BOATS 2023



**WIDE PORTFOLIO
OF BOATS**



QUALITY



SAFETY



FREEDOM OF MOVEMENT



SERVICE



ECOLOGY

INDEX

Materials	7
Smart features	10

KAYAKS 12

RUSH	14
THAYA	16
TWIST	18
SWING	20
SOLAR	22
FRAMURA	24
SEAWAVE	26
SAFARI	28
K2	30

CANOEES 32

RUBY XL	34
PALAVA	36
BARAKA	38
SCOUT	40

BOATS AND RAFTS 42

ONTARIO	44
COLORADO 450	46
PULSAR	48

FISHING BOAT 50

HALIBUT	52
ALFONSO	54

OTHERS 56

Paddles	56
Accessories	58
Clothes	60
Technical data	62

LEGEND



Max. number of persons



Weight

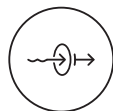

Self-draining bottom with a roll-top seal



Self-draining bottom



Motor attachment



Grade 1. Fast moving water with ripples and small waves.



Grade 2. Straightforward rapids with wide, clear and evident channels. Clearly visible rocks or other obstructions with medium-sized waves.



Grade 3. Rapids with moderate, irregular large waves which may be difficult to avoid. Strong eddies and powerful current effects.



Grade 4. Intense, powerful rapids requiring precise boat handling in turbulent water. It may feature large, unavoidable waves and holes.



Grade 5. Extremely difficult rapids with obstructions and dangerous currents. Drops may contain large, unavoidable hazards.



Drop-stitch technology used in the boat.



Maximum load

THE EXPERIENCE BEGINS
WITH A CHOICE



WE HAVE EVERYTHING UNDER CONTROL



We're the only company in the world that produces boats starting with the raw material itself. What comes into the factory are only textiles, raw rubber and additives. What leaves is a complete boat - tested several times and packaged. Everything takes place here, in Břeclav in the Czech Republic, in the EU. We obviously adhere to all fair employment and environmental protection policies.

WE HAVE SOMETHING FOR EVERYONE

Are you looking for a small light kayak for one, a family kayak or a large raft?
We've got it all - the choice is yours.
You're not sure?
Let us know, we'll be happy to help.



WE'LL TAKE YOUR PETS FOR A RIDE



Our materials have stood the test of dog paws and claws. Take your four-legged friends along for the ride - they're sure to enjoy it just as much as you!

ENOUGH ROOM FOR EVERYONE ON BOARD

Dear paddlers,
Have you ever been kicked in the back when sitting in a boat, or even gotten hit with a paddle? When designing our boats, we keep the necessary space for paddling and maneuvering in mind. You'll enjoy a comfortable ride with plenty of room.



WHEN THE BOAT'S ALL PACKED UP, IT'S EASY TO CARRY, IT FITS IN THE TRUNK OF YOUR CAR AND ON BOARD A PLANE

Most of our boats are delivered in a waterproof backpack that you can throw over your shoulder and set out for an adventure. Now, that's freedom.

When compared to PVC, our rubberized boats can be packed into smaller dimensions, which you're sure to appreciate since it won't get in the way and you'll save plenty of space.

NO WAY OF GOING UNDER

Our boats are made from highly durable materials. Each boat has at least 3 air chambers. If an accident does occur leading to the deflation of one of the air chambers, the two remaining chambers will keep you afloat. You're safe with us.



WE USE NATURAL RUBBER TO MAKE OUR BOATS – IT'S ECO-FRIENDLY AND EASY TO FIX

One of the fundamental materials used in the production of boats can be found between the bark and wood of the Para rubber tree. Thanks to the superb properties of natural and synthetic rubber blends, which we develop ourselves, our boats are extremely durable. The material is flexible, and doesn't succumb to breaks in folds even when stored for a longer period of time. In case there is a puncture, you'll easily be able to fix it with the repair kit supplied with all boats. You'll manage it easily and without breaking a sweat.



WE ARE AVAILABLE TO YOU

We know our boats to the very last thread – we control their production starting with the development of materials. We are able to secure spare parts for models that we no longer offer. Everything takes place under one roof with a great deal of handcraft. Our warranty and post-warranty service is available to you for the boat's entire lifespan. We're here for you.

ON THE WATER TOGETHER FOR ALMOST 70 YEARS



The long-term experience and know-how that we've been able to acquire over this time help us to produce unique inflatable boats. Our own in-house development allows us to experiment with new materials and search for new ways of improving the utility value of the boats. The cooperation with experts in the field as well as fellow paddlers keeps moving us forward. That's why you'll always get a wonderfully designed and tested boat from us.

See you out on the water!

THE SECRET TO OUR BOATS' STRENGTH

We make everything from the beginning and so we have developed our own fabric based on natural rubber which guarantees excellent boat durability. Our boats are resistant to abrasion, aging and sunlight.

DOUBLE-SIDED NITRILON®

Material composition: high-strength PES fabric (1) with a double-sided synthetic rubber coating (2). The material is highly resistant to abrasion, aging and UV light. Tensile strength min. 3 000/3 000 N (sample 20 × 5 cm). Minimum weight 1 192 g/m².

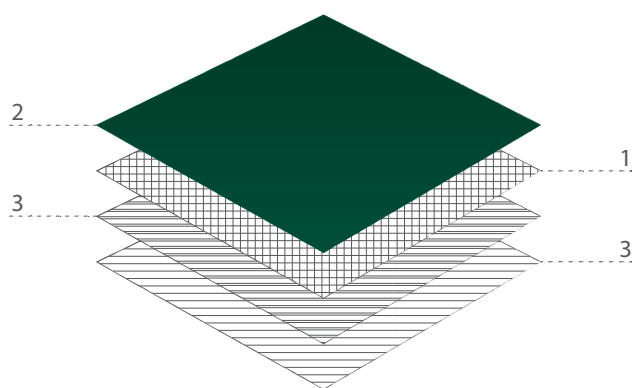
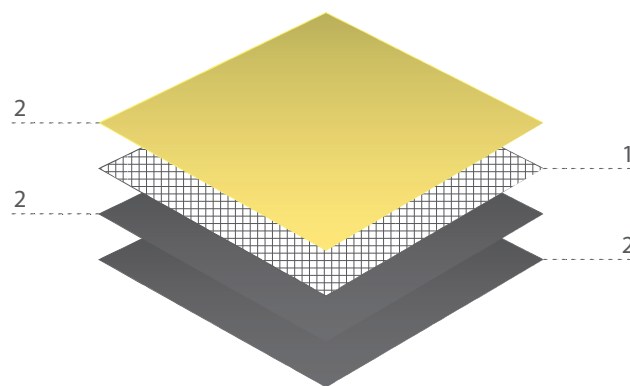

NITRILON®

Material composition: high-strength PES fabric (1) with an outer synthetic rubber coating (2) and inner natural rubber blend coating (3). The material is highly resistant to abrasion, aging and UV light. Tensile strength min. 3 000/3 000 N (sample 20 × 5 cm). Minimum weight 920 g/m².

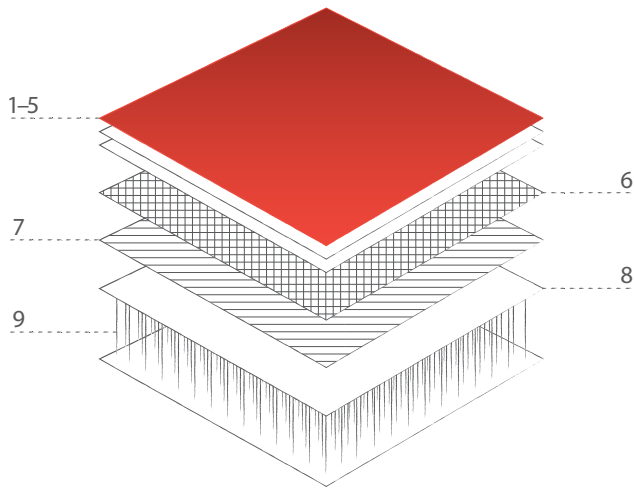

NITRILON® + DROP-STITCH

Material composition: outer coating based on synthetic rubber (1), anchoring layer (2), high-strength PES cloth (1 100 dTex) (3), anchoring layer (4), natural and synthetic rubber coating (5), natural and synthetic rubber coating (6), anchoring layer (7), drop-stitch top sheet (9). Minimum tensile strength is 3 600/3 100 N (20 × 5 cm sample). Minimum weight is 1 270 g/m².

NITRILON® EXTRA

Material composition: high-strength PES fabric (1) with an inner and outer layer of synthetic rubber (2) coating and outside NITRILON® EXTRA (3) coating. A top quality material for maximum load and for use in demanding climatic conditions.

Tensile strength min. 3 000/3 000 N (sample 20 × 5 cm).

Minimum weight 1 487 g/m².

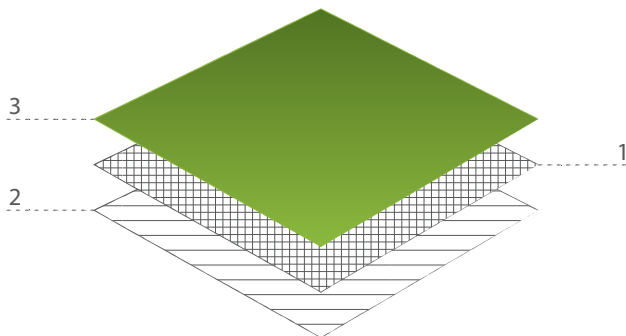
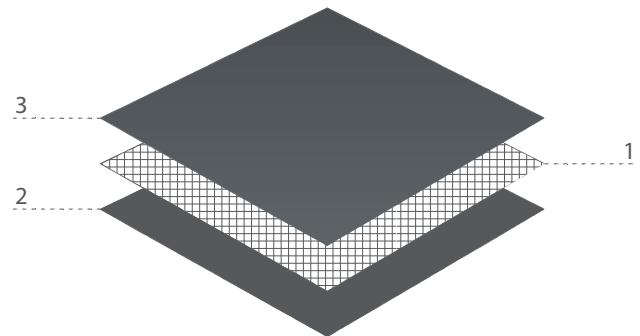

PES PUR

Material composition: PES fabric of RIPSTOP (1) type with an inner polyurethane layer (2) and Teflon water-repellent finish (3). The material is resistant to abrasion, aging and UV light. Minimum pull strength 1 100/900 N (sample 20 × 5 cm).



SMART FEATURES

SOLID BOTTOM USING DROP-STITCH TECHNOLOGY

The bottom of the boat is reinforced by thousands of fibers connecting its inner walls. Thanks to this feature the boat is very stable and difficult to capsize.

Featured on THAYA and RUSH kayaks.

drop-stitch material

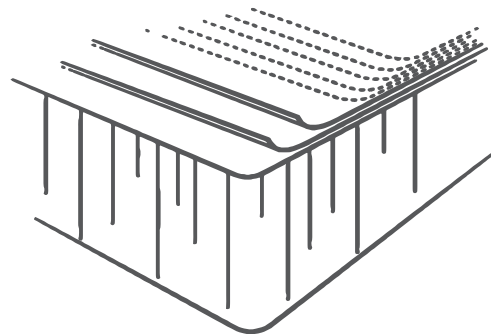

TRACKING FIN HELPS TO STEER COURSE

The tracking fin makes it much easier to control the kayaks. Ensuring the boat tracks well and maintains good directional stability.

Featured on THAYA, RUSH, TWIST, SWING, SOLAR, FRAMURA, SEAWAVE, SAFARI 330 and HALIBUT kayaks.



SELF-BAILING BOTTOM WITH A ROLL-TOP SEAL

Got water on deck? Thanks to the self-bailing floor design, water will drain away without effort. The rolling closure allows the floor to be sealed for calm water use.

Featured on BARAKA and SCOUT boats.

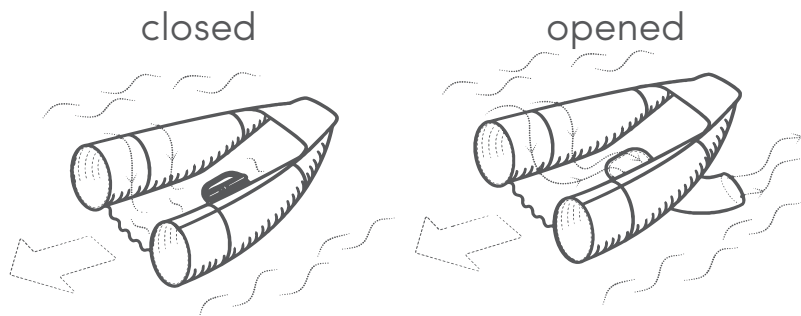

T-BONE REINFORCEMENTS

Metal reinforcements placed under the seats serve to shape and reinforce the bottom of the boat. Actually, the inflatable boat gains the performance characteristics of a hard-shell canoe.

Featured on SCOUT canoe.

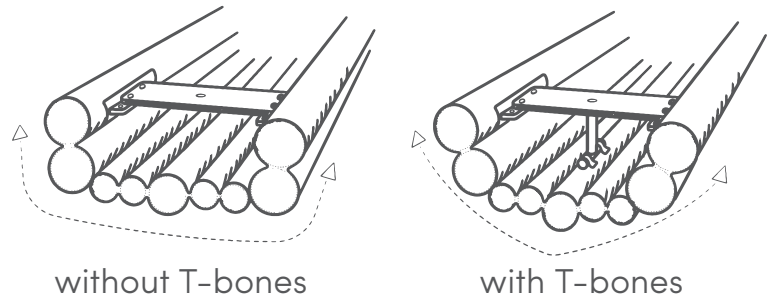

SELF-BAILING BOTTOM WITH DRAINAGE HOLES

Unobtrusive holes in the bottom of the boat will ensure you stay dry through more ferocious rapids with water draining immediately.

Featured on SAFARI 330, K2, ONTARIO 450S and PULSAR boats..

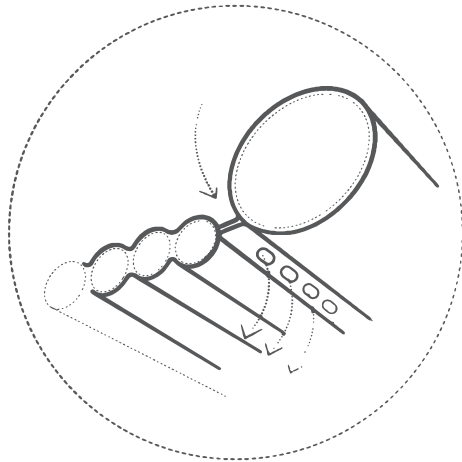

self-draining holes

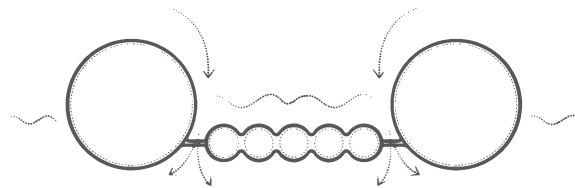

COMFORT ABOVE ALL ELSE

Even if you attach a third seat to your SEAWAVE, SOLAR or THAYA kayaks, each paddler will still have plenty of room and comfort. We respect the rules, and so all our boats comply with legal standards. As for boat capacity, we often supercede the standards.

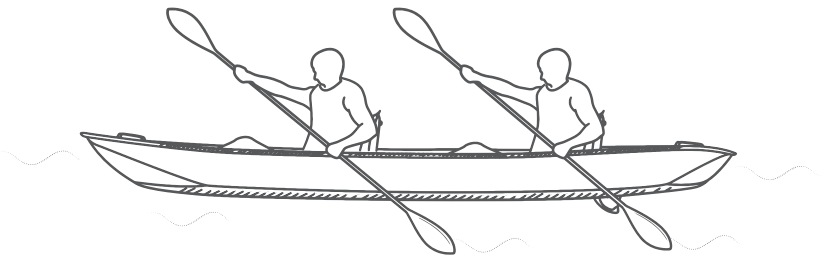



 GUMOTEX

BOATS FOR EVERY OCCASION

Inflatable kayaks are stable, safe, easy to use and easy to pack. Recreational kayaks are designed for paddling on calm water such as lakes or coastal estuaries. White-water kayakers are designed for experienced paddlers for river descents with a higher degree of difficulty.

Rush



page 14

Solar



page 22

Framura



page 24

Thaya



page 16

Seawave



page 26

Two



page 18

Safari



page 28

Swing



page 20

IK₂



page 30

Rush

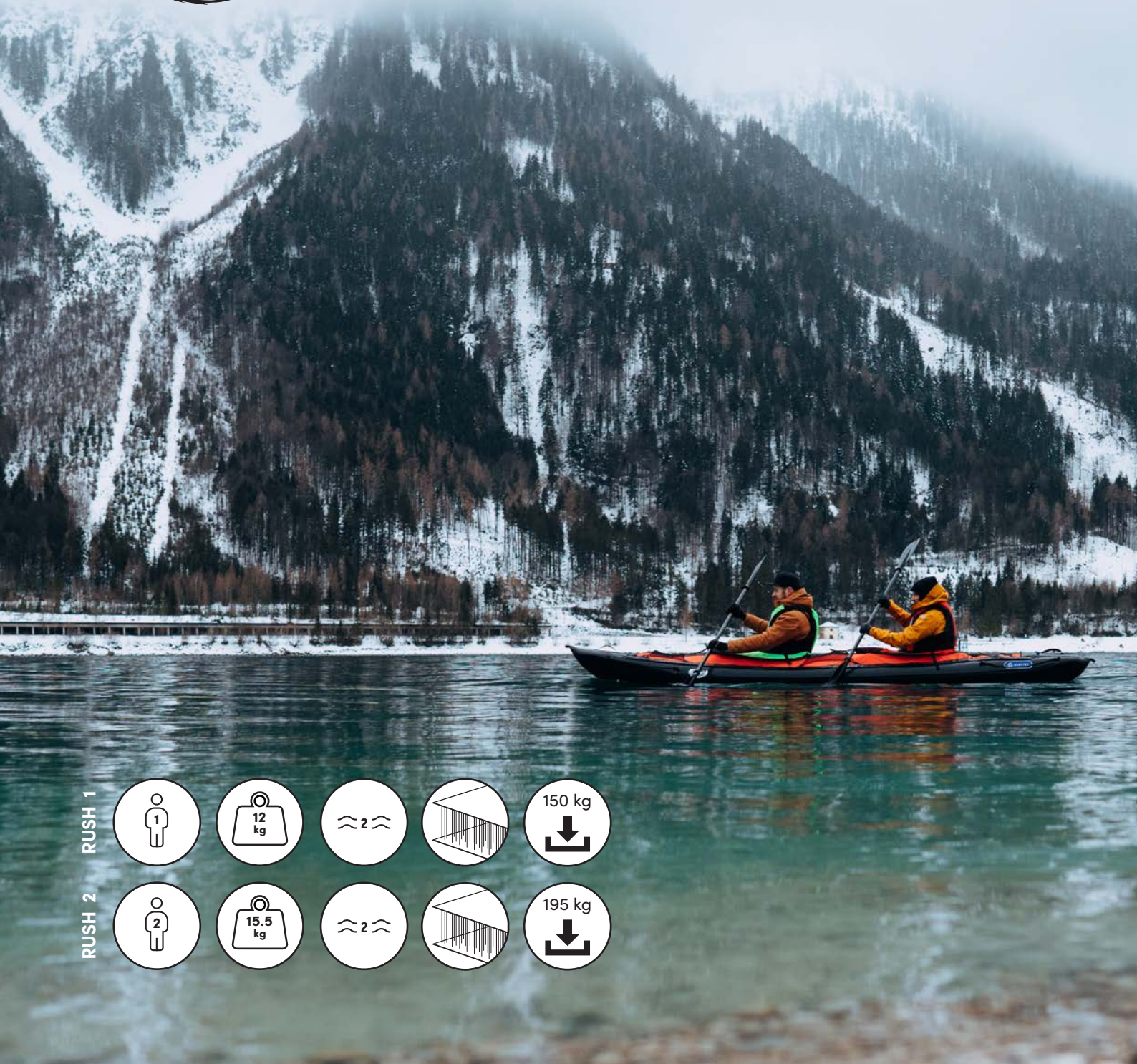

RUSH 1



RUSH 2



FUTURE SOLVED...



comfortable seat and backrest constructed from PE foam

deck rigging for fixing baggage

carry handles for easy manipulation

drop-stitch bottom



fixture for tracking fin

tracking fin

safety ropes on the bow and stern

An innovative and versatile kayak design which further expands the possibilities of **drop-stitch** technology (hydrodynamically designed bow and keel). The **RUSH** is suitable for recreation, touring, calm lakes, coastal waters as well as navigating white water up to grade 2. For better comfort in poor weather conditions, it can be equipped with a rudder or a removable cockpit (recommended accessories). The main advantages are versatility, speed and stability.

The **RUSH 2** kayak can be used as a single or as a double kayak.

Drop-stitch technology is based on the connecting the upper and lower layers of the fabric with thousands of polyester fibers. This fabric, equipped with an airtight coating, is protected from both sides by a resistant **NITRILON®** material.

Thanks to the thousands of fibers holding both layers together, these products can be inflated up to very high pressure. It enables the material to obtain robustness approaching the robustness of solid materials.

Thaya



A KAYAK WITH AN INFLATABLE, SOLID BOTTOM

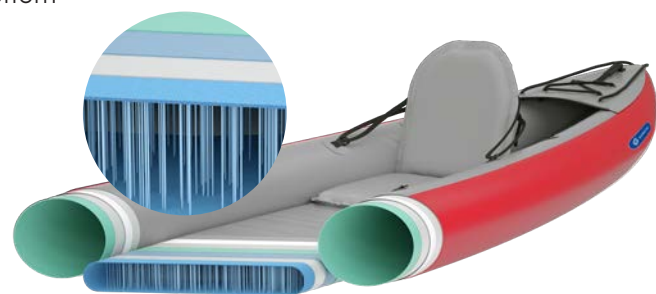
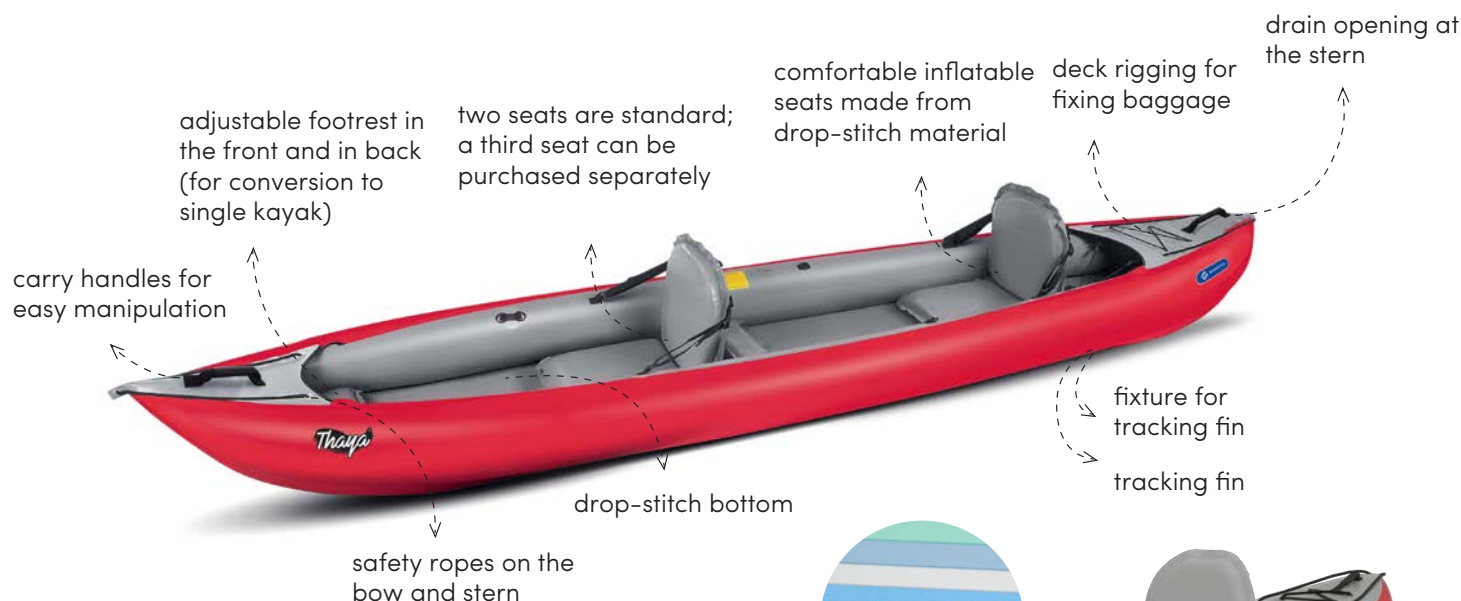

The revolutionary **THAYA** inflatable kayak uses a combination of our special **NITRILON®** material with **drop-stitch** technology and is defined by its excellent stability, stiffness and maneuverability. The unique combination of the inflatable side tubes and modern **drop-stitch** technology creates an universal combination which maximizes the user's comfort and improves the handling properties of the boat. Light-weight and easy to pack away: the added benefits of the **THAYA**.

It is suitable for recreational paddling on lakes, gentle coastal waters and rivers up to grade 2. Seating positions can be adjusted for 1, 2 adults or 2 adults + 1 child. An optional foredeck splash cover offers protection for the front paddler and prevents water from flowing over the bow.

TWIST



TWIST 1



TWIST 2/1



A LIGHTWEIGHT KAYAK FOR EVERYONE

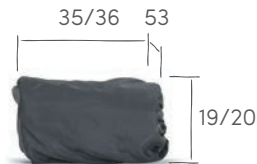
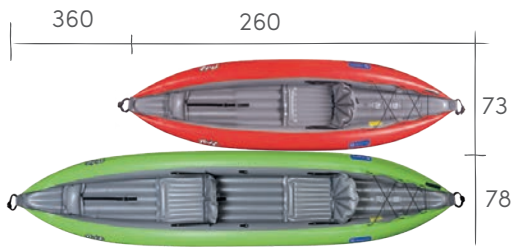

Are you looking for a small, lightweight, space-saving kayak as a companion on the road and your watersport adventures? Then the **TWIST** is the right choice for you, whether you're exploring new places on lakes or travelling on calm rivers. The **TWIST 1** is the smallest and the lightest kayak from our

fleet.

The **TWIST 2/1** can be easily transformed from its two-seat version to its one-seat version or vice versa, thanks to an innovative design. The kayak is stable enough for a variety of paddler sizes, and comfortably fits two people.

SWING



SWING 2 SWING 1



A STABLE PARTNER FOR TRICKY SITUATIONS

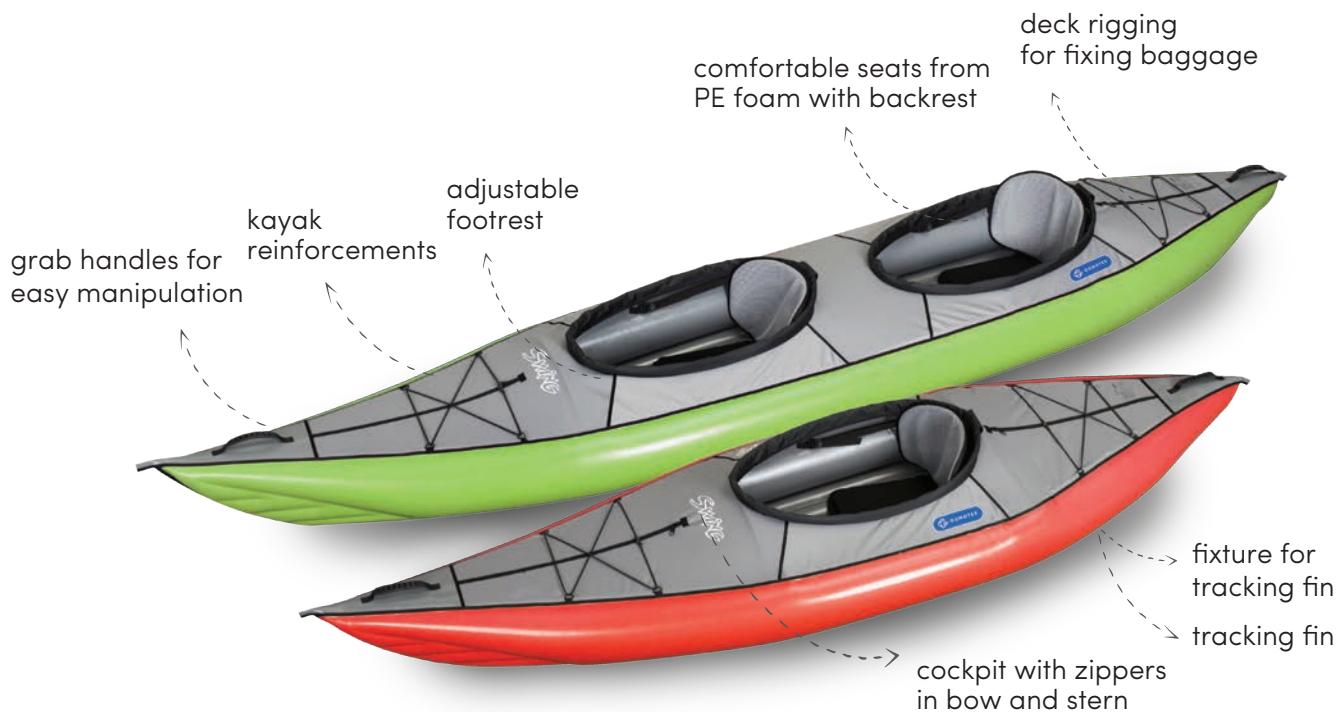
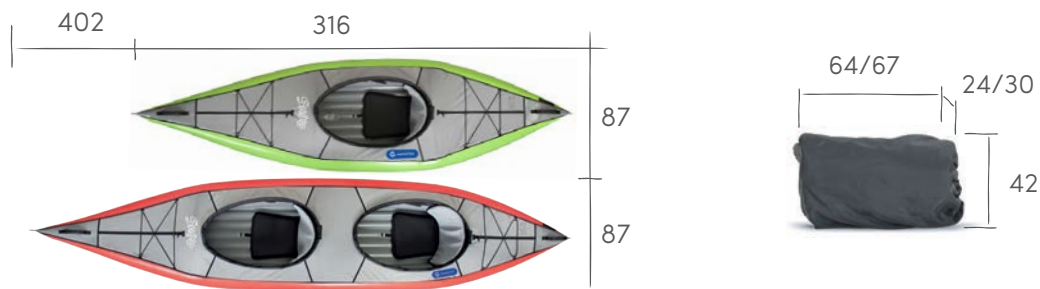

The **SWING** is a sit-in inflatable kayak great for relaxing trips on sheltered waters, harbours, lakes and rivers up to grade 2. The kayak is supplied with two aluminium reinforcements for improved rigidity of the hull, maneuverability and stability.

The reinforcements also shape the deck of the kayak. Thanks to its low weight, the kayak is perfect for trips with frequent portages. The kayak is available in a single and a double version.

Solar



A FAMILY KAYAK THAT ALMOST PADDLES ITSELF

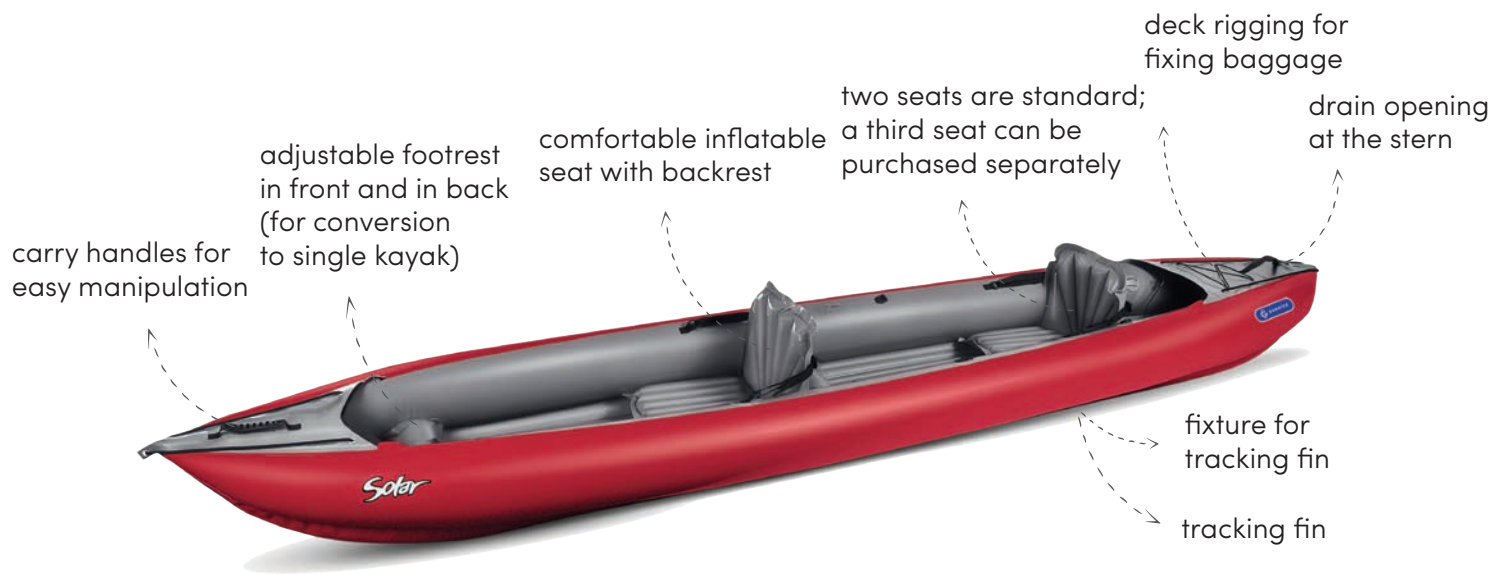
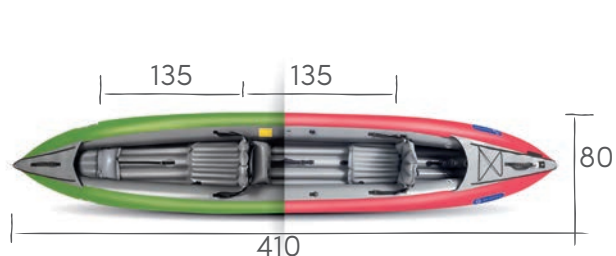

The **SOLAR** inflatable kayak serves for both trips on lakes and touring on rivers up to grade 2. An optional foredeck splash cover offers protection from the elements for the front paddler and prevents water from flowing over the bow. The kayak is equipped with a drainage hole in the rear deck.

The **SOLAR** is equipped with two seats and fixtures for an optional third seat. As a result, the **SOLAR** boasts versatility with paddling setups for solo, tandem or 2+1 use.

Framura



THE FASTEST GUMOTEX KAYAK

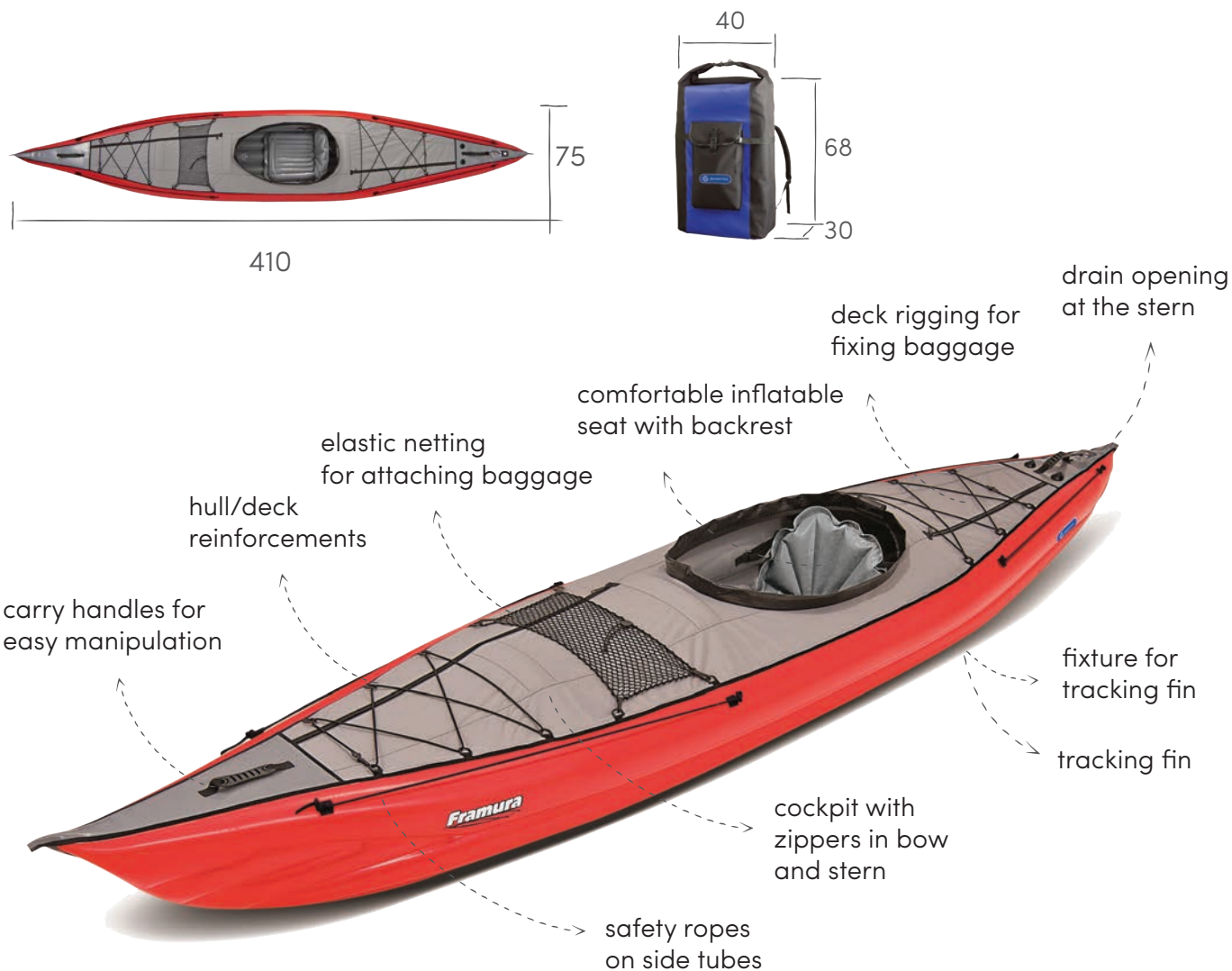

The **FRAMURA** is the fastest kayak produced by GUMOTEX. It is designed for leisure and touring and is suitable for sheltered waters, harbours, inlets and lakes as well as calm rivers up to grade 1.

The **FRAMURA** has carrying capacity in the front and rear. The kayak has a fixed deck, elastic netting and a comfortable inflatable seat: it's a feature-rich touring kayak with an optional spray skirt and rudder. A sea-kayak paddle is the ideal choice for the **FRAMURA**.

Seawave



THE ULTIMATE GUMOTEX TOURING KAYAK

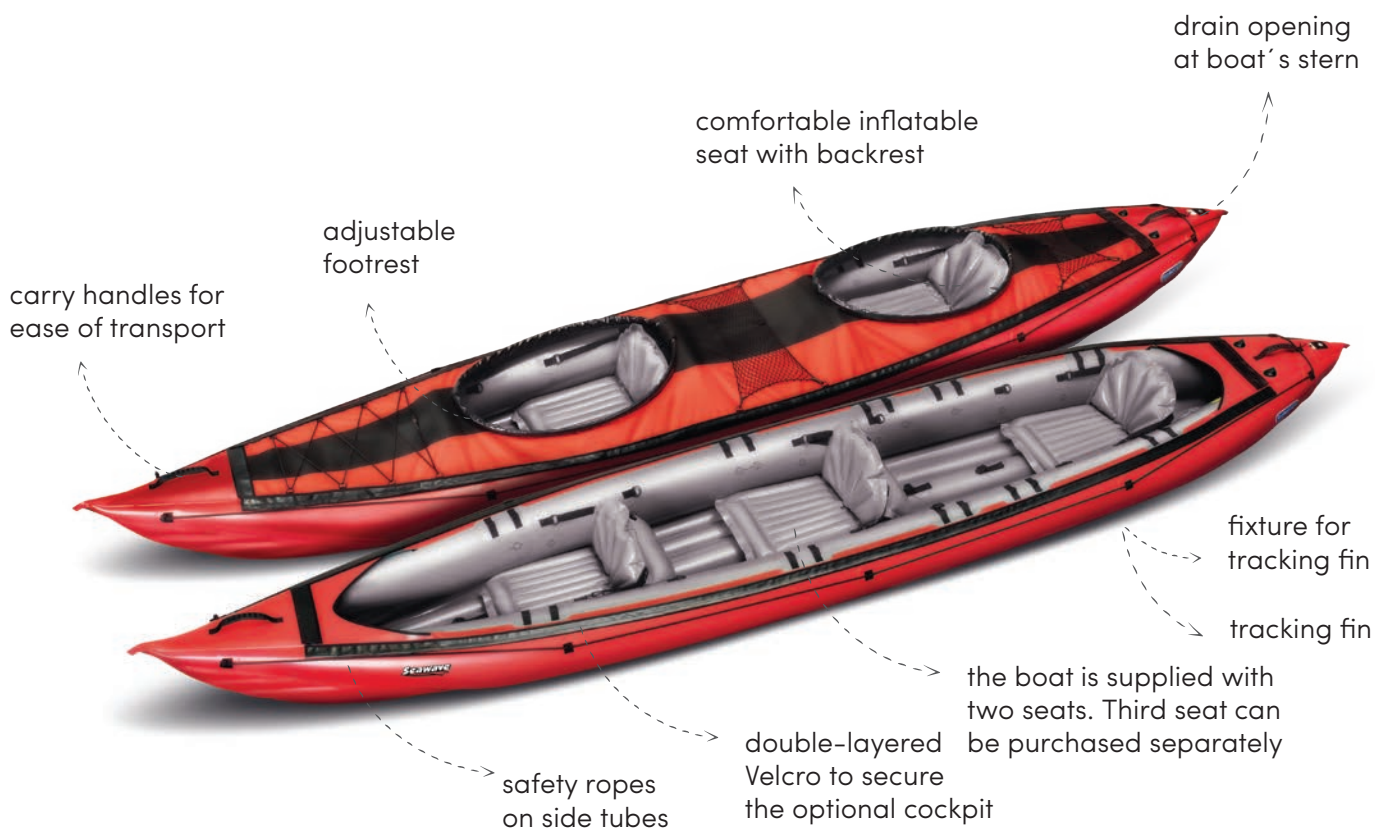
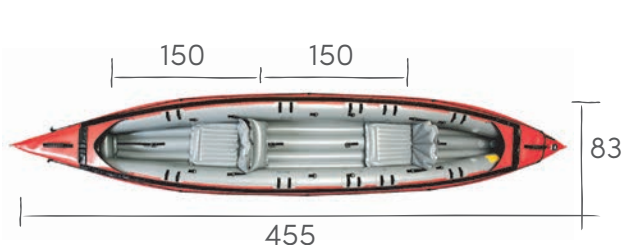

Thanks to its long narrow shape, the **SEAWAVE** kayak is easy to control and very fast. It can be converted from a three-person version into a two-person or one-person kayak by moving the seats. Installation of an optional deck makes the **SEAWAVE** a great sea kayak.

Aluminium reinforcements support the deck and stiffen the kayak. The floor features a pronounced keel for handling in the wind and better tracking.

The **SEAWAVE** is an excellent touring kayak suitable also for seakayaking in sheltered waters.

Safari



FUN KAYAK FOR RIVERS AND SEA SURFING

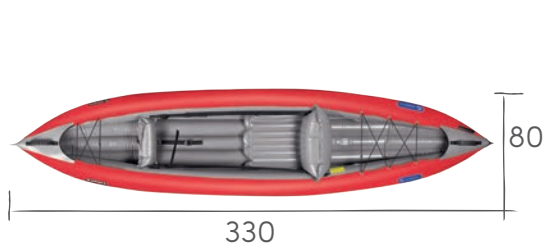

The **SAFARI 330** is a sports kayak with a self-bailing bottom suitable for rivers up to grade 3 white water, coastal kayaking or surfing. The new **SAFARI 330** is longer, wider and more stable than its precursor. It is spacious enough

to fit well-built kayakers and thanks to significantly improved stability, it's also suitable for less experienced paddlers. The stern and bow can accommodate dry bags with your personal gear. Elastic ropes secure the bags in place.

K₂



K2



DURABLE WHITE WATER KAYAKS

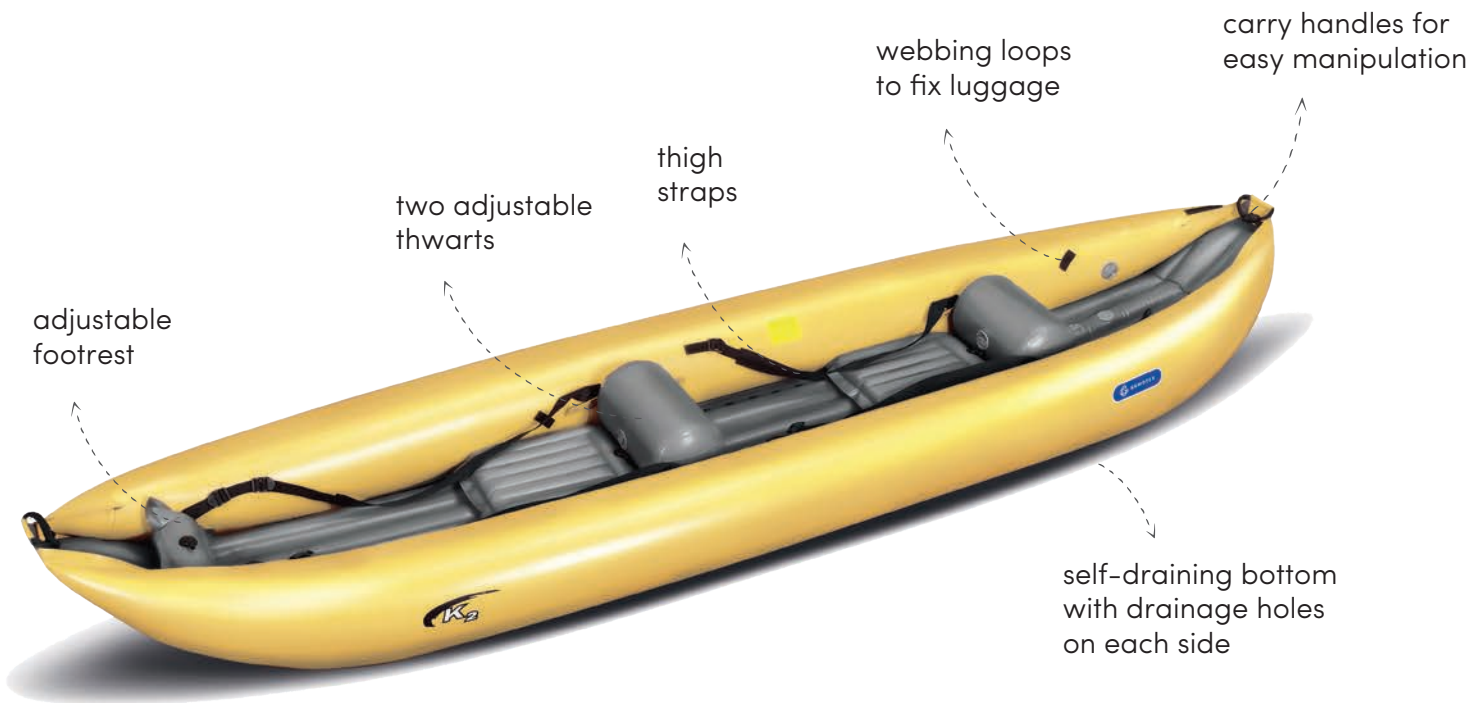
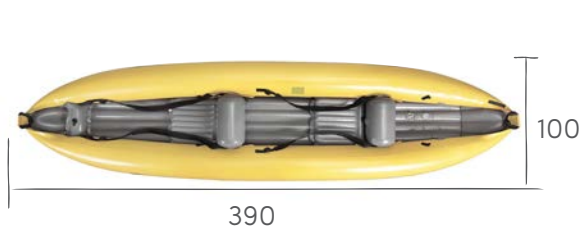

The **K2** is an inflatable kayak with a self-bailing floor designed specifically for white water. The kayak is very stable and forgiving inspiring confidence in novice kayakers, even on more technical runs.

The **K2** offers ample seating space and an inflatable seat(s) for comfort plus thigh straps for better control of the kayak in rapids.



AN IDEAL PARTNER FOR LONG JOURNEYS

Inflatable canoes are safe, easy to use and easily packable. They excel in their speed and agility, and also have plenty of storage space. Inflatable canoes are intended primarily for overnight trips and exploring waters with a lower degree of difficulty.

RubyXL

page 34



Baraka

page 38



Palava

page 36



Scout

page 40



RubyXL



RECREATIONAL BOAT WITH OPTIONAL MOTOR ATTACHMENT



The new, larger **RUBY XL** is 17cm wider than the original version while maintaining excellent handling performance. It can be used with oars, with paddles as a canoe, or with a motor. The fastening of the transom has also been improved: it's much more robust and can be fitted with a motor not exceeding 5 hp or 3.7 kW.

The **RUBY XL** is suitable for recreational coastal use, or just trips on lakes and quieter watercourses. With canoe paddles (i.e. without a motor or oars), this boat can be used for river cruising up to the grade 2.

(the motor used must have a short shaft and a maximum weight of 28 kg)

Palava



EVERGREEN OF EUROPEAN RIVERS

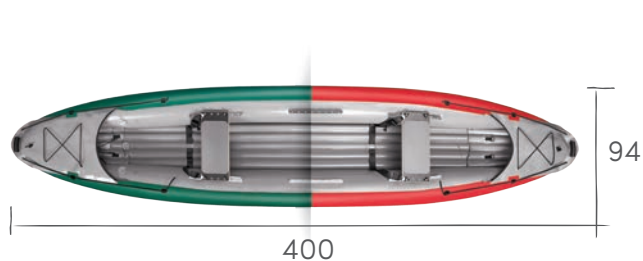

The **PALAVA** inflatable canoe is eye catching with its sporty look and excellent handling performance. Thanks to its longer hull, it offers a storage space and flexible seat positioning, providing comfort for anyone. When riding in rapids, it is possible to kneel and use the thigh straps.

The canoe is suitable for river cruising up to the grade 3 as well as for a comfortable touring on placid natural and artificial lakes.

Baraka



SPORTS CANOE WITH PLENTY OF SMART FEATURES

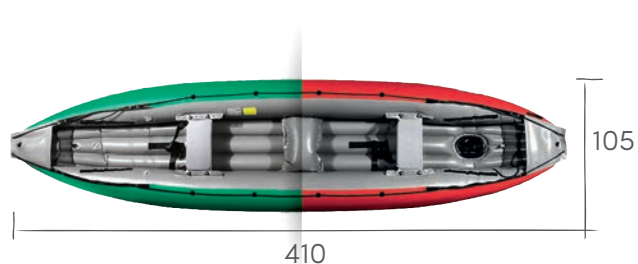

The **BARAKA** is a river canoe with a self-bailing floor that can handle white water up to grade 4. The boat has a rigid hull that handles well in rapids. The **BARAKA** provides its crew with many useful features and fittings and with plenty of space inside.

The boat is designed for two adults plus one child, up to a maximum load of 350 kg. The **BARAKA** is the right choice for paddlers, who are looking for a boat designed without compromises.

Scout



SCOUT



COMFORTABLE CANOE FOR LONG EXPEDITIONS

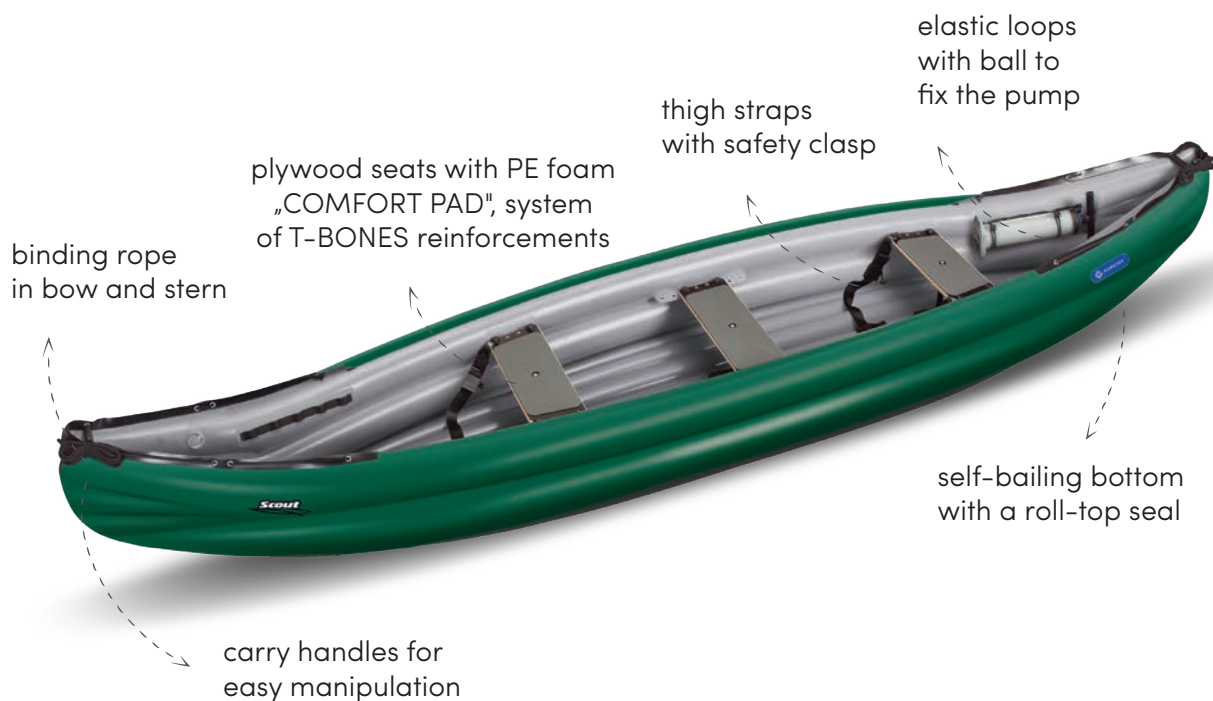
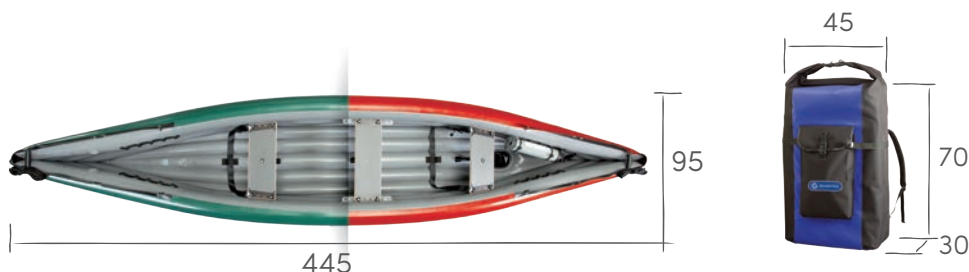

SCOUT is an inflatable canoe with a modern design. The boat offers plenty of features for the paddler's comfort and convenience, such as large inner space combined with huge payload and smooth handling. **SCOUT** makes an ideal boat for adventures with plenty of carrying capacity,

suitable for white water enthusiasts or for family trips. **SCOUT** brings an innovative system of T-BONES reinforcements that strengthen the boat's floor and provide great handling qualities comparable with a rigid canoe.



BOATS CAPABLE OF TACKLING THE TOUGHEST WHITEWATER RAPIDS

Inflatable boats and rafts from this category are designed for both experienced paddlers to take on rapids and for multi-day trips with the whole family or a group of friends. These boats are robust, durable and safe. We have equipped them with a self-bailing bottom and numerous safety elements. We recommend using a buoyancy aid, helmet and suitable clothing.

Ontario

page 44



PULSAR

page 48



Colorado

page 46



Ontario



ONTARIO
450 S



OUR FASTEST MULTI-SEATER

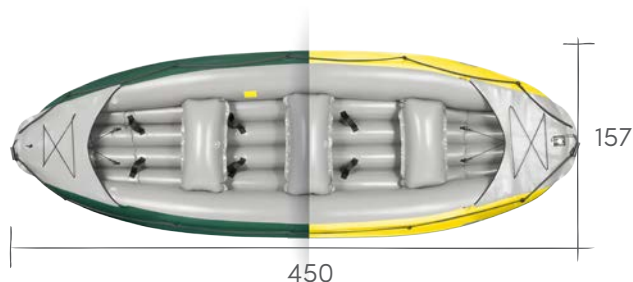

ONTARIO 450 S is a six-person boat suitable for multi-day trips on rivers with the whole family. **ONTARIO** is easy to control, fast and nimble. The **ONTARIO 450 S**

is a self-bailing boat that can handle white water up to Gr. 3. **ONTARIO 450 S** is a versatile boat suitable for everyone.

Colorado



MULTI-PURPOSE PERFORMANCE BOAT

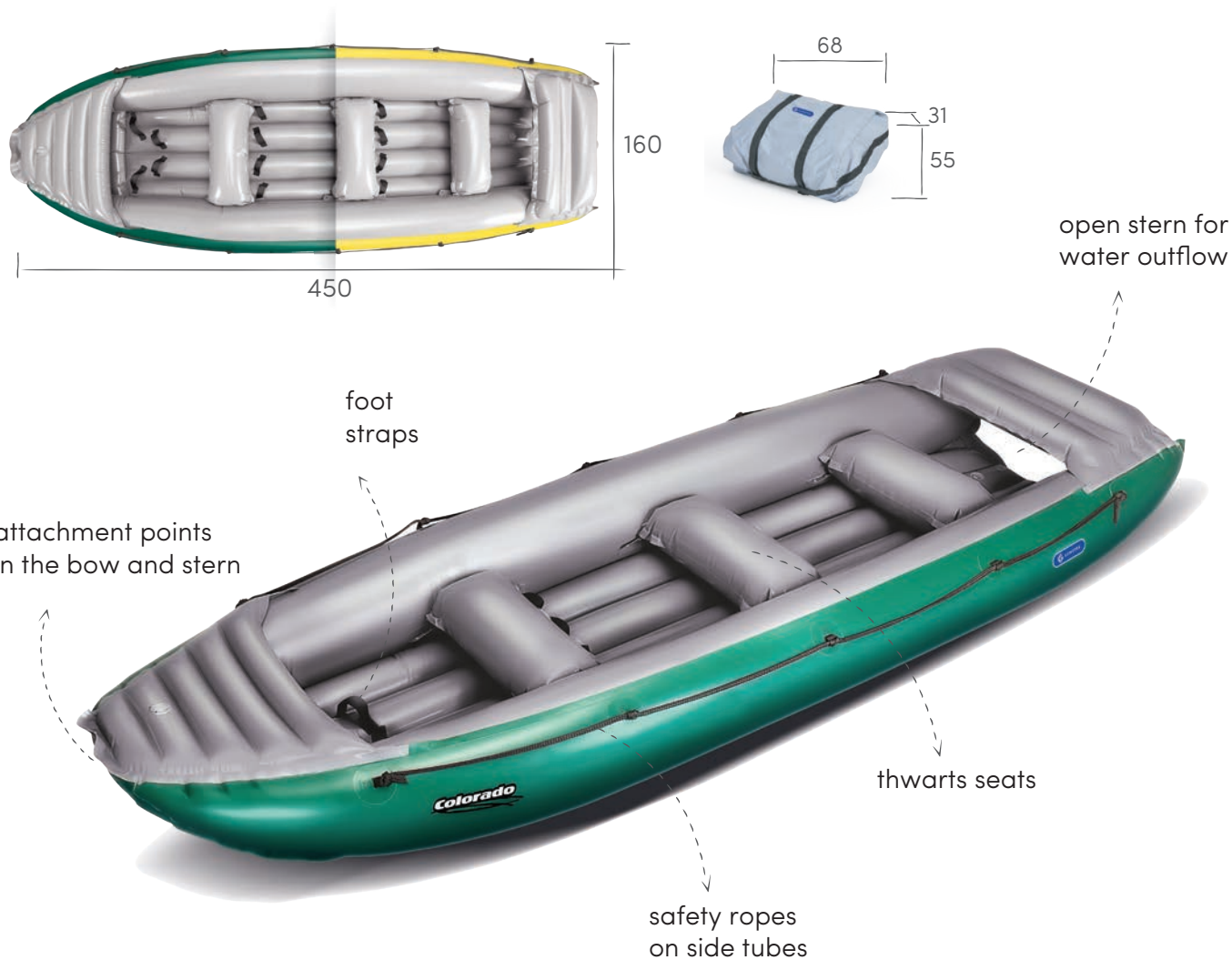

The **COLORADO 450** is a multi-purpose boat. This six-person boat is great for river cruising or performance white water with experienced paddlers. The open stern provides the outflow of water in rapids.

The legendary **COLORADO** has served on many expeditions into remote places around the world and is still a very popular team racing river boat in the Czech Republic.

PULSAR



PULSAR
380



PULSAR
450



PULSAR
420



PULSAR
560



RAFT FOR THE TOUGHEST CONDITIONS

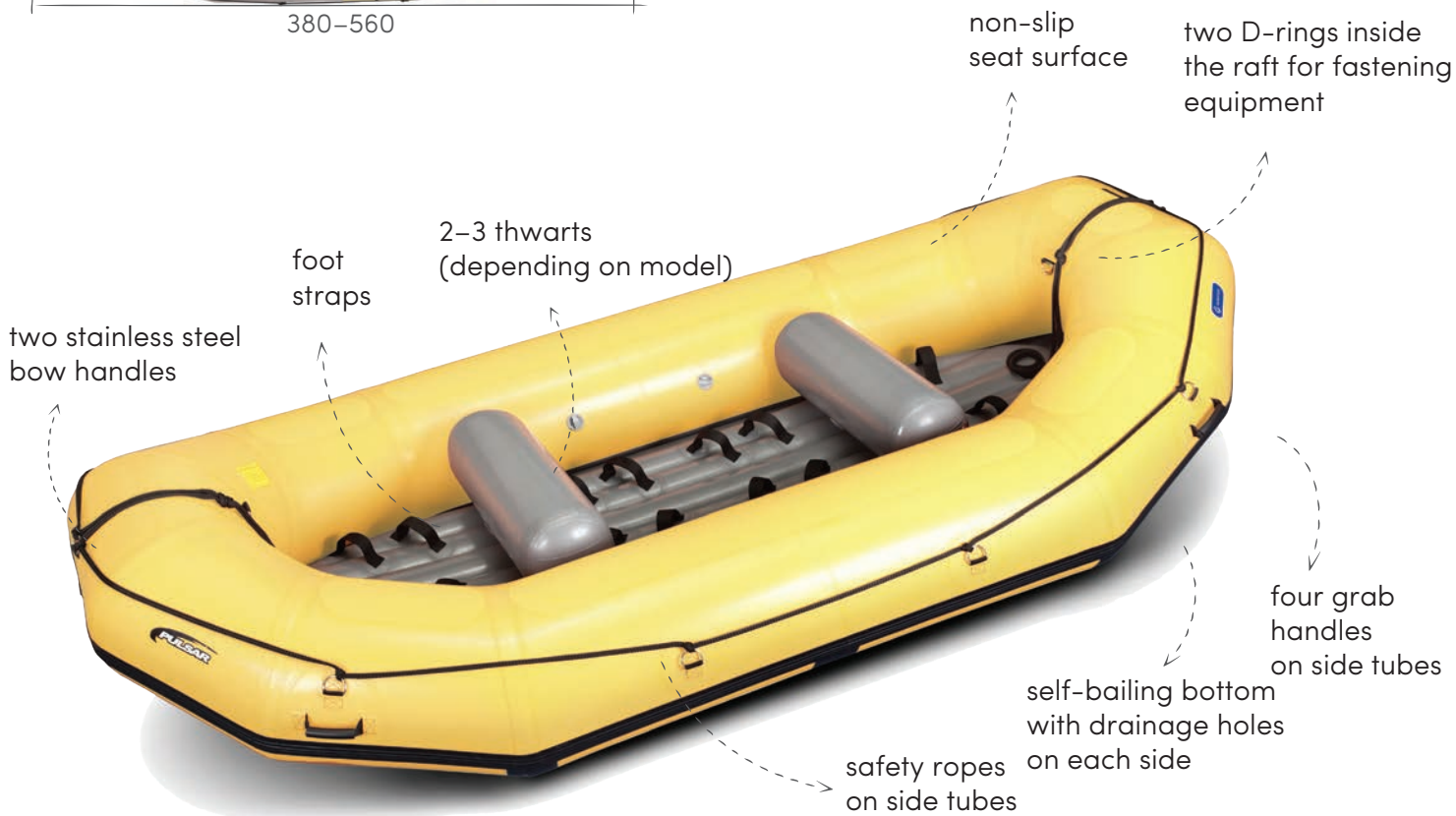
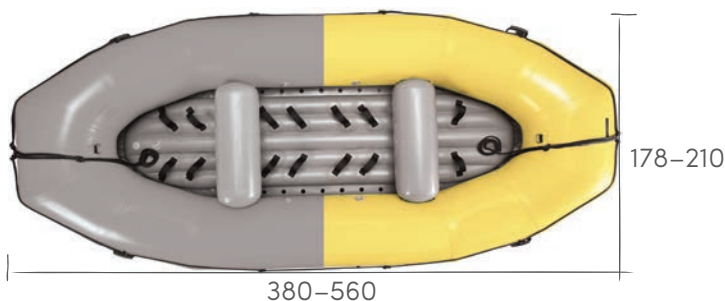

The **PULSAR** is a sought-after model by rafting operators, sports centres, water sports clubs as well as for raft racing. The fast and rigid hull combined with the self-bailing inflatable bottom provides exceptional stability and very fast draining in rapids. **PULSAR** rafts have been chosen

several times as the official race boats for the European Championships (most recently for the European Rafting Champs 2016 in Slovenia) and also the official race boat for the 2003 World Championships that took place in the Czech Republic on the Vltava River.



BEST FOR PASSIONATE FISHERMEN

The GUMOTEX inflatable fishing boats are designed for recreational and sports fishing. The boats provide a platform from which to fish. The main feature is stability – it enables standing up while casting the line. The supplied accessories include comfortable inflatable seats with backrest, rod holders and other fishing equipment. The boats pack up in the carry bag provided and is easy to carry or store.

Halibut



page 52

Alfonso



page 54

Halibut



UNIQUE FISHING KAYAK



The **HALIBUT** is an inflatable fishing kayak, offering a new dimension in the sport of angling. Thanks to its compact dimensions when packed, it is possible to enjoy kayak fishing even in remote locations. The **HALIBUT** is very stable, responsive and fast when moving on the water.

The inflatable kayak floor is fitted with a marine plywood standing platform. A raised adjustable seat makes for easy embarking and disembarking and also provides comfort while waiting for a catch.

Alfonso



Alfonso



COMFORT BOAT FOR FISHERMEN



The updated **ALFONSO** fishing boat is mainly distinguished by its excellent stability and plenty of space for up to 3 passengers (or 2 fishermen). It can be used with oars, with paddles as a canoe, or in combination with a motor. The fastening of the transom has also been improved, which is now much more robust and can be fitted with a motor with the maximum power up to 5 hp = 3,7 kW. A new addition – the boat has 5 bases for mounting a wide range of holders and fasteners for accessories (4 bases are placed on the side tubes because of a greater practicality, so

they do not reduce the interior space of the boat, and the 5th base is intended for the eventual positioning on the middle or rear seat). This boat is suitable for white water up to Gr. 2 using paddles alone.

(the motor used must have a short shaft and a maximum weight of 28 kg)

PADDLE



PADDLE 504 RAFTGUIDE

Rafting paddle with
a blade surface area
of 985 cm²

Length:
145, 150, 160, 170 cm

Weight:
0.88 – 0.965 kg
(depending on length)



CANOE PADDLE 505 ALLROUND

Canoe paddle with
a blade surface area
of 802 cm²

Length:
145, 150, 160, 170 cm

Weight:
0.72 – 0.90 kg
(depending on length)
505.0 one-piece,
505.2 two-piece,
505.3 three-piece



KAYAK PADDLE 702 ALLROUND

Traditional kayak
paddle with an
asymmetrical blade,
blade surface area
709 cm²

Length:
200 – 240 cm
10 cm increments

Weight:
1.145 – 1.385 kg
(depending on size)
702.0 one-piece,
702.2 two-piece,
702.3 three-piece

PADDLE TYPE 702.3 FISHING

Three-piece paddle
260 cm long
designed for the
HALIBUT fishing
kayak.

Length:
260 cm

Weight:
1.55 kg



PADDLE 703.2 SEA

Classic double touring
paddle for lakes and
sea touring, paddle
blade surface area
626 cm²

Length:
200–240cm
10 cm increments

Weight:
1.24 kg (depending
on length)



PADDLE 801 COMBINATION

Either 1 kayak paddle or 2 canoe paddles can be assembled from this folding paddle, 736 cm² blade surface.

Kayak paddle length:
180 – 240 cm
10 cm increments

Canoe paddle lengths:
145 and 155 cm

Weight:
1.31 kg (depending on length)



KAYAK PADDLE 719S.2

A double paddle on glass laminate spar with carbon-reinforced ends for increased breaking strength. The blade area is 559 cm²

Length:
210 – 240 cm
10 cm increments

Weight:
0.94 kg
(depending on length)



PLD.0 FOR HALIBUT

One-hand paddle for the HALIBUT.

Length:
72 cm



OARS 902.2

Length:
190cm

Weight:
2 kg



KAYAK PADDLE 379S.2

New development in our series of kayak paddles: A double paddle on glass laminate spar. The paddle can be adjusted in various angles and length from 230 to 240 cm.

Variable length:
230–240 cm

Weight:
0.96 kg



ACCESSORIES



Transport drybag
80 l, 100 l, 135 l



Expedition transport
100 l



Drybag for storing equipment
20 l, 40 l, 60 l



Drybag for small items
8 l, 12 l, 20 l



RUSH 1, 2 deck



SEAWAVE deck for 1 and 2
people



RUSH, SWING, SEAWAVE,
FRAMURA spray skirt



Double-action
hand pump 2/4



Double/single-action hand pump
3.2/6.4



RAFTER 51
single-action hand pump



BRAVO 230/1000
electric air pump



THAYA, SOLAR
additional front deck



UV-Tech product for treatment
of inflatable kayaks and boats



Push-Push valve
(0.2 Bar)



Modified Push-Push
valve reduction



Safety relief valve



Pressure gauge for
Push-Push valve



HOBBY/PROFI valve wrench for
Push-Push and overpressure valve



GUMOTEX safety throw-bag



BORIKA
fishing rod holder



CANNON
fishing rod holder



NITRILON
repair kit



ELASTICK
adhesive 250 ml



Tracking fin



FRAMURA rudder



SEAWAVE rudder



RUSH rudder

CLOTHES



GUMOTEX paddle helmet

This watersports helmet is very light and comfortable. The adjusting system makes the helmet highly universal and it fits almost everyone. This version includes ear protection.



Neoprene shoes protect your feet from cold water and sharp rocks.



GUMOTEX neoprene socks

Neoprene socks are made of 3 mm-thick neoprene with abrasion resistant material on the outside.



Life jacket



Child life jacket



GUMOTEX neoprene trousers

The trousers are made of 3 mm neoprene. They provide good warmth and flexibility during watersports. Thanks to the two-way zipper in the front and short zippers on the ankles, it's put on and taken off very easily. Exposed areas are protected with PU coating.



TECHNICAL DATA

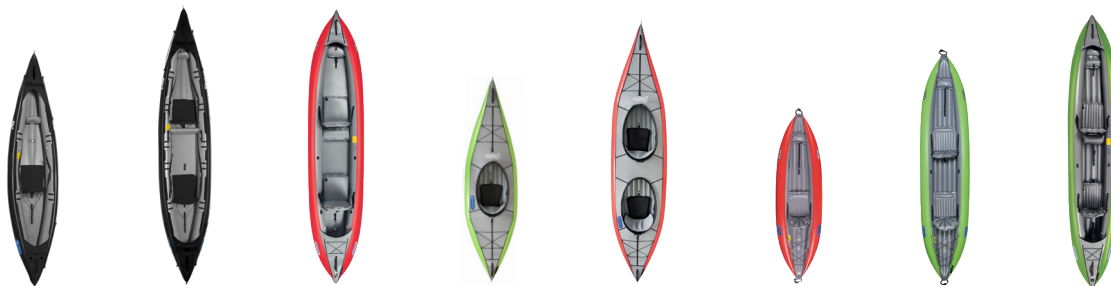

	RUSH 1	RUSH 2	THAYA	SWING 1	SWING 2	TWIST 1	TWIST 2/1	SOLAR
Length (cm)	355	420	410	316	402	260	360	410
Width (cm)	81	82	89	87	87	73	78	80
Air chambers	3+1	3+2	3 + 2 / 4 / 6 + 2	3	3	3 + 2	3 + 3	3 + 2 + 2
Max. operation pressure (bar)	0,025/0,25/3,75 0,05/0,5/7,2	0,025/0,25/3,75 0,05/0,5/7,2	0,02/0,2/3,0 0,05/0,5/7,2	0,02/0,2/3,0	0,02/0,2/3,0	0,02/0,2/3,0	0,02/0,2/3,0	0,02/0,2/3,0
Packed dimensions (cm)	65 × 40 × 28	69 × 48 × 28	63 × 40 × 26	64 × 42 × 24	67 × 42 × 30	53 × 35 × 19	53 × 36 × 20	54 × 39 × 24
Weight (kg)	12	15,5	17,5	11,3	14,3	9	13	16
Max. load (kg)	150	195	230	120	220	90	170	270
Max. number of persons	1	2	2 + 1	1	2	1	2	2 + 1
Material	NITRILON®	NITRILON®	NITRILON®	NITRILON®, PES, PUR	NITRILON®, PES, PUR	NITRILON®	NITRILON®	NITRILON®
Color	6 11C	6 11C	5C 11C	5C 11C 1C 11C	5C 11C 1C 11C	5C 11C 1C 11C	5C 11C 1C 11C	5C 11C 1C 11C
Difficulty	grade 2	grade 2	grade 2	grade 2	grade 2	grade 1	grade 1	grade 2
Accessories	Tracking fin, Transport drybag 100 l, Repair kit, Valve wrench for Push-Push and overpressure valve	Tracking fin, Transport drybag 100 l, Repair kit, Valve wrench for Push-Push and overpressure valve	Tracking fin, Transport drybag 100 l, Repair kit, Valve wrench for Push-Push and overpressure valve	Tracking fin, Transport bag made from textile, Repair kit, Valve wrench for Push-Push and overpressure valve	Tracking fin, Transport bag made from textile, Repair kit, Valve wrench for Push-Push and overpressure valve	Tracking fin, Transport bag made from textile, Repair kit, Valve wrench for Push-Push and overpressure valve	Tracking fin, Transport drybag 80 l, Repair kit, Valve wrench for Push-Push and overpressure valve	
Recommended accessories	Paddle 719S.2 GTX hand pump 2/4 Cockpit RUSH 1 or RUSH 2 Drybag for small items 8 l, 12l, 20 l RUSH rudder (only Rush 2)		Kayak paddle 719S.2 GTX hand pump 2/4 Additional front deck Drop-stitch seat THAYA Drybag for small items	Spray skirt Kayak paddle 702 asymmetric GTX hand pump 2/4 Transport drybag 100 l Drybag for small items		Kayak paddle 702 asymmetric GTX hand pump 2/4 Drybag for small items	Kayak paddle 702 asymmetric GTX hand pump 2/4 Seat SOLAR Drybag for small items Additional front deck	

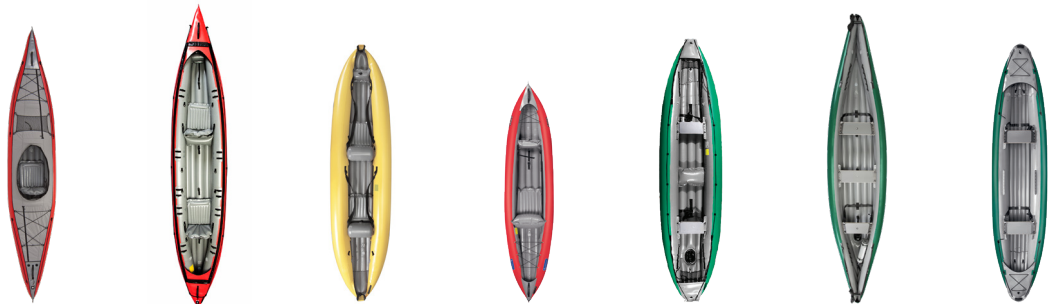

	FRAMURA	SEAWAVE	K2	SAFARI 330	BARAKA	SCOUT	PALAVA
Length (cm)	410	455	390	330	410	445	400
Width (cm)	75	83	100	80	105	95	94
Air chambers	3 + 1 + 1	3 + 3 + 2	3 + 2 + 3	3 + 1 + 2	3 + 1	3	3
Max. operation pressure (bar)	0,02/0,2/3,0	0,025/0,25/3,7	0,025/0,25/3,7	0,02/0,2/3,0	0,02/0,2/3,0	0,02/0,2/3,0	0,02/0,2/3,0
Packed dimensions (cm)	68 × 40 × 30	68 × 43 × 30	70 × 45 × 30	53 × 38 × 24	70 × 43 × 30	70 × 45 × 30	60 × 40 × 25
Weight (kg)	16	17,5	20	12	23,5	25	17,5
Max. load (kg)	180	250	200	130	350	450	240
Max. number of persons	1	3	2	1	2 + 1	3 (2 + 2)	2 + 1
Material	NITRILON®, PES, PUR	NITRILON®	NITRILON® DS	NITRILON®	NITRILON®	NITRILON®	NITRILON®
Color							
Difficulty	grade 1	grade 2	grade 4	grade 3	grade 4	grade 3	grade 3
Accessories	Tracking fin, Transport drybag 100 l, Repair kit, Valve wrench for Push-Push and overpressure valve	Tracking fin, Transport drybag 135 l, Repair kit, Valve wrench for Push-Push and overpressure valve	Tracking fin, Transport drybag 135 l, Repair kit, Valve wrench for Push-Push and overpressure valve	Tracking fin, Transport drybag 80 l, Repair kit, Valve wrench for Push-Push and overpressure valve	Transport drybag 135 l, Repair kit, Valve wrench for Push-Push and overpressure valve	Transport drybag 135 l, Repair kit, Valve wrench for Push-Push and overpressure valve	Transport drybag 100 l, Repair kit, Valve wrench for Push-Push and overpressure valve
Recommended accessories	Spray skirt, Paddle 703.2 sea, GTX hand pump 3.2/6.4, FRAMURA rudder, Drybag for storing equipment	Spray skirt, Paddle 719S.2, GTX hand pump 3.2/6.4, Seat SEAWAVE, SEAWAVE cockpit for 1 or 2 persons, SEAWAVE rudder Drybag for storing equipment	Kayak paddle 702 asymmetric, GTX hand pump 3.2/6.4, Drybag for storing equipment, GUMOTEX safety throw-bag	Kayak paddle 702 asymmetric, GTX hand pump 2/4, Drybag for storing equipment	Canoe paddle 505 allround, GTX hand pump 3.2/6.4, Drybag for storing equipment, GUMOTEX safety throw-bag	Canoe paddle 505 allround, GTX hand pump 3.2/6.4, Seat PALAVA, Drybag for storing equipment	

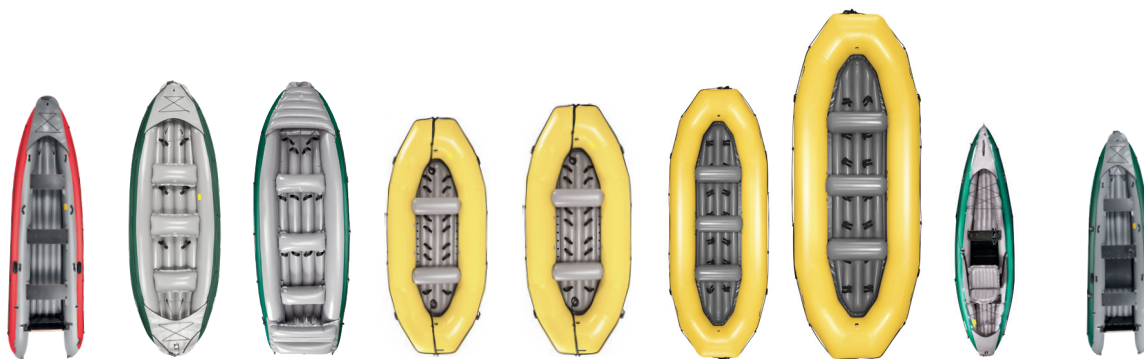

	RUBY XL	ONTARIO 450 S	COLORADO 450	PULSAR 380N	PULSAR 420 N	PULSAR 450 N	PULSAR 560 N	HALIBUT	ALFONSO
Length (cm)	430	450	450	380	420	450	560	375	430
Width (cm)	125	157	160	178	190	210	210	96	125
Air chambers	3	3 + 3	3 + 5	5 + 2	5 + 2	5 + 3	5 + 3	3 + 1	3
Max. operation pressure (bar)	0,02/0,2/3,0	0,02/0,2/3,0	0,02/0,2/3,0	0,025/0,25/3,7	0,025/0,25/3,7	0,025/0,25/3,7	0,025/0,25/3,7	0,02/0,2/3,0	0,02/0,2/3,0
Packed dimensions (cm)	68 × 51 × 29	67 × 58 × 30	68 × 55 × 31	80 × 65 × 40	85 × 65 × 40	90 × 70 × 35	100 × 70 × 50	70 × 46 × 30	68 × 55 × 30
Weight (kg)	29	30	37,5	44	50	60	75	21	32,7
Max. load (kg)	410	630	600	650	800	900	920	200	410
Max. number of persons	3	6	6	7	8	9	12	1	3
Material	NITRILON®	NITRILON®	NITRILON®	NITRILON® DS, NITRILON® Extra	NITRILON® DS, NITRILON® Extra	NITRILON® DS, NITRILON® Extra	NITRILON® DS, NITRILON® Extra	NITRILON®	NITRILON
Color	5 C 11 C	2 A 11 C 13 11 C	2 A 11 C 13 11 C	2 A 11 C 11 C	2 A 11 C 11 C	2 A 11 C 11 C	2 A 11 C 11 C	13 11 C	13 11 C
Difficulty	grade 2	grade 3	grade 4	grade 5	grade 5	grade 5	grade 4	grade 1	grade 2
Accessories	Transport dry-bag 135 l, Repair kit, Valve wrench for Push-Push and overpressure valve	Transport bag, Repair kit, Valve wrench for Push-Push and overpressure valve	Transport bag, Repair kit, Valve wrench for Push-Push and overpressure valve		Transport bag, Repair kit, Valve wrench for Push-Push and overpressure valve			Tracking fin, Transport drybag 100 l, Repair kit, Valve wrench for Push-Push and overpressure valve	Tracking fin, Transport drybag 135 l, Repair kit, Valve wrench for Push-Push and overpressure valve
Recommended accessories	Oars 902.2, Canoe paddle 505 allround, GTX hand pump 3.2/6.4, Electric or combustion engine, Drybag for storing equipment	Canoe paddle 505 allround, GTX hand pump 3.2/6.4, Drybag for storing equipment	Canoe paddle 505 allround, GTX hand pump 3.2/6.4, Drybag for storing equipment, GUMOTEX safety throw-bag		Canoe paddle 504 raftguide, Single-action hand pump RAFTER 5I, Abrasion resistant foil, Drybag for storing equipment, GUMOTEX safety throw-bag			Kayak paddle 702 asymmetric, GTX hand pump 2/4, Drybag for small items	Oars 902.2, GTX hand pump 3.2/6.4, Electric or combustion engine, Drybag for storing equipment

**GENTLE TO NATURE,
FRIENDLY TO PADDLERS**



